

# 8 Misconceptions About Embedded CDMOs

Author: Karen Lauxmann, Contract Manufacturing European Sales Lead, Pfizer CentreOne

Can collaborating with an embedded CDMO like Pfizer CentreOne benefit my drug program?

Yes, it can. You may have a few misconceptions about the embedded model so let's have a look at those and how they align with our **Pfizer values** – courage, excellence, equity and joy.

1.

## My Intellectual Property (IP) may be compromised

We take partner IP protection very seriously. At Pfizer CentreOne, we've been manufacturing partner products alongside our own for decades. All our customers' products are subject to the same strict IP policies and all our staff are trained in information-handling compliance.

#equity

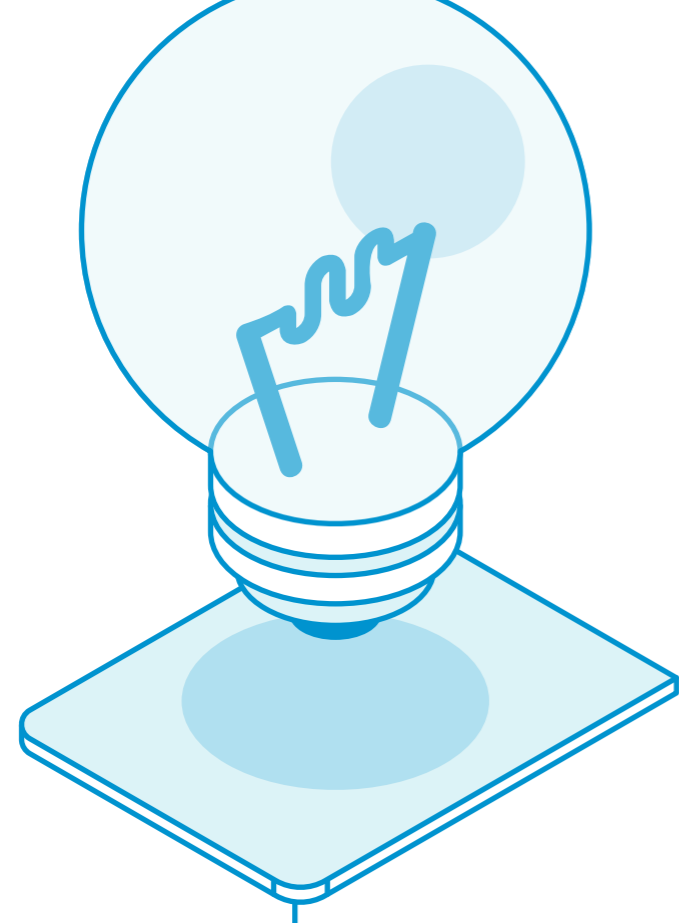

2.

## Parent company projects will be prioritized over my program

We deliver the same technical and quality expertise, great science, and global regulatory support to our external partners that Pfizer products receive. Always. Pfizer operates Pfizer CentreOne as a profit center with a dedicated team and resources. The capacity we reserve is fully dedicated to our customers.

#excellence

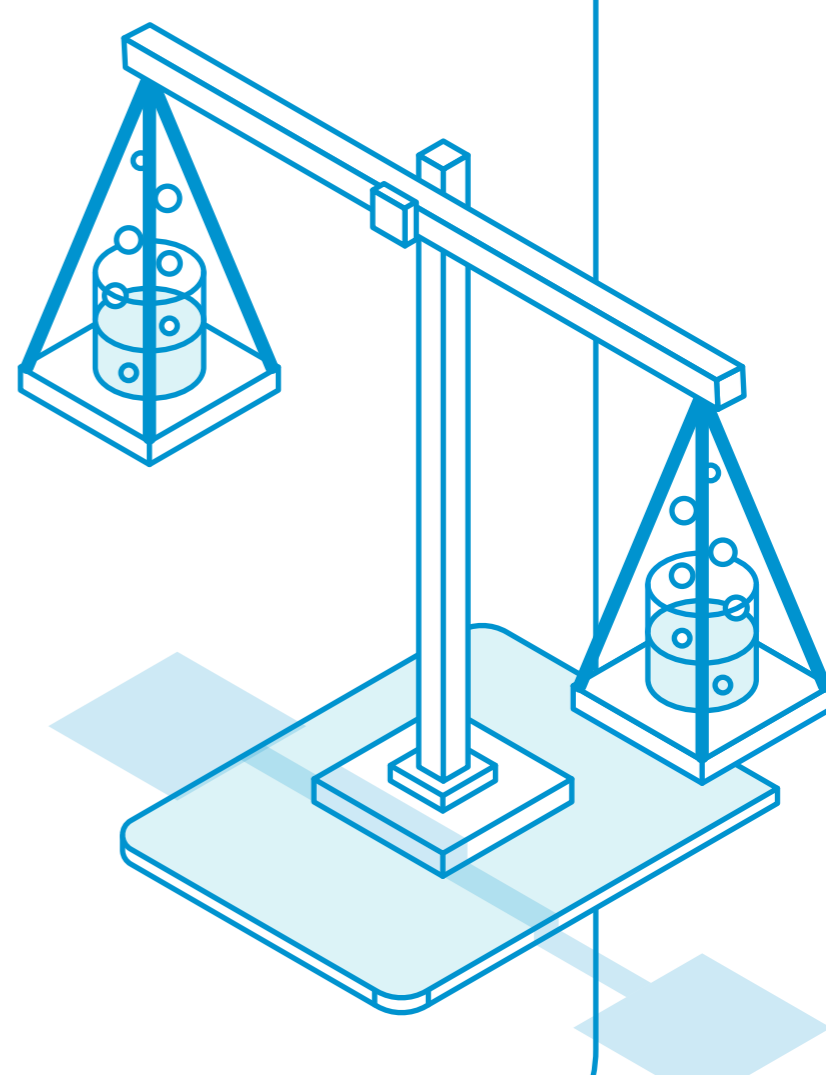

3.

## You're just looking to fill up excess capacity

All CDMOs, embedded or not, are there to market available capacity and support customers with expert science and operational excellence.

#excellence

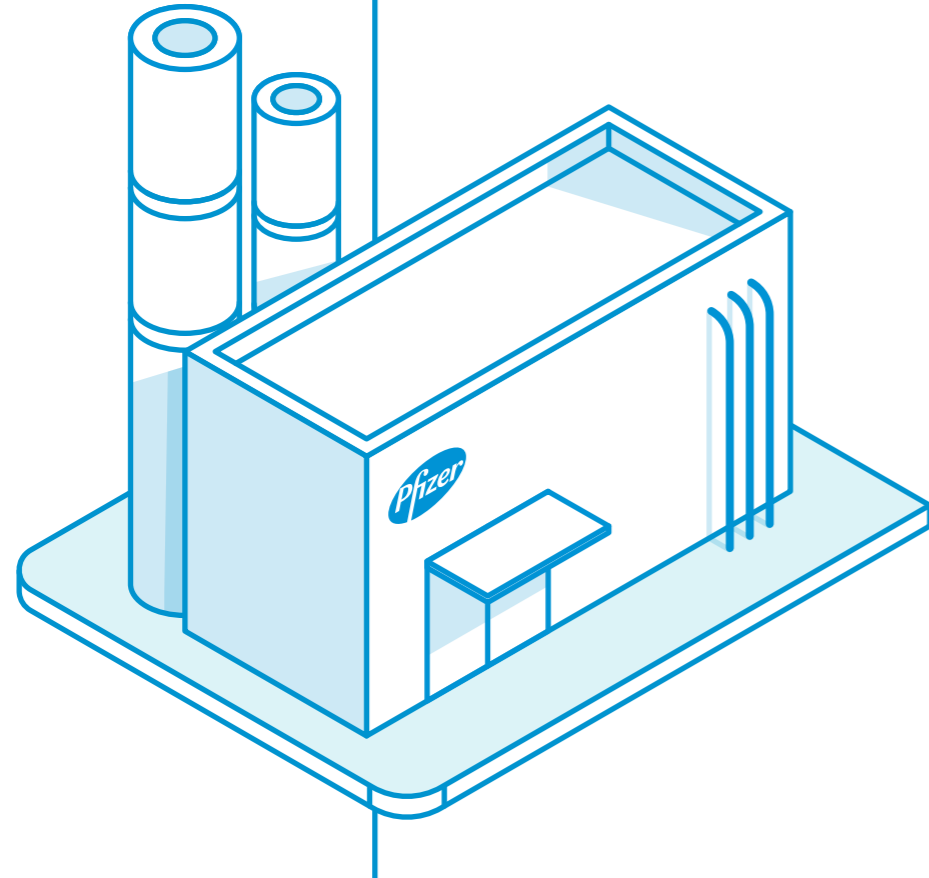

4.

## I won't have access to the wider Pfizer global network and expertise

Being embedded within Pfizer means that we can take full advantage of Pfizer's global manufacturing network and some of the industry's brightest scientific minds. We also benefit from Pfizer's ability to make significant investments in its facilities. For example, Pfizer has invested \$1 billion in its API and drug product pharmaceutical manufacturing plant in Kalamazoo, Michigan over the last decade, adding to the impressive network of global facilities and resources.

#courage



5.

## Embedded CDMOs have higher cost-structures and therefore, higher prices

Drug program costs are subject to many variables and external factors. Pfizer Global Supply has developed a manufacturing cost structure to produce any drug product as effectively and cost efficiently as possible. Our global network's capabilities allow continuous improvements and efficiencies.

#excellence



6.

## You won't be as customer-service oriented as a pure-play CDMO

Contract manufacturing partnerships depend on excellent customer service and the success of any program requires close collaboration, responsiveness and clear communication – a trusted partnership. We have a dedicated team of professionals who bring their best selves each day because our work is personal and positive customer experience is a priority. We have several API contract partnerships that have been maintained for many years.

#joy

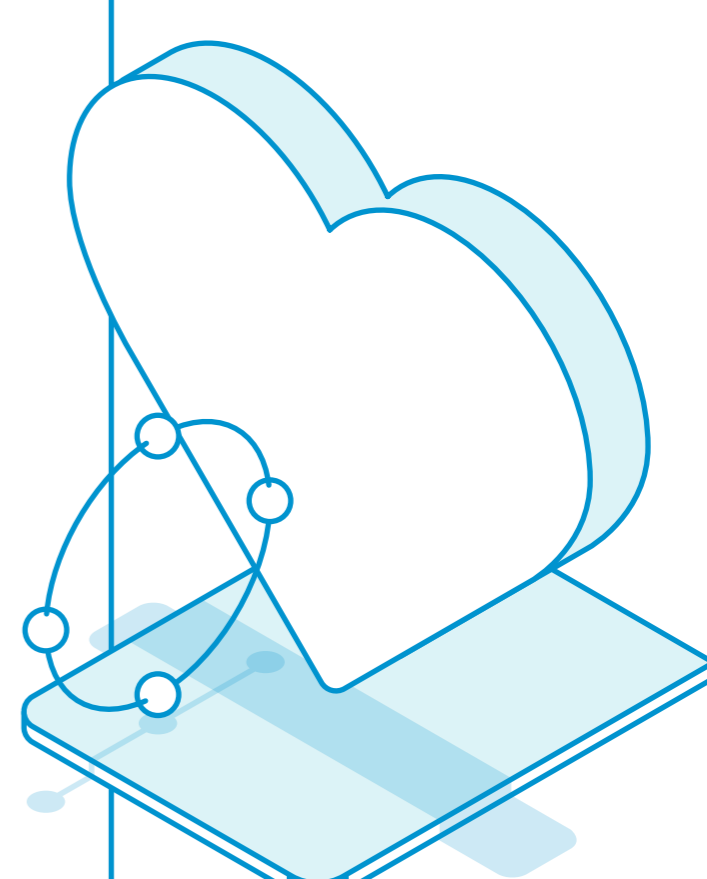

7.

## You might not be agile enough for my drug's patient population or strategy

In drug development, agility comes from experience. We're embedded in Pfizer's 170-year legacy. Few CDMOs can offer the range and depth of experience with the understanding of exactly what it takes to bring breakthroughs that save patients' lives. That said, not every project is the right fit and we are open enough to admit when that's the case.

#courage

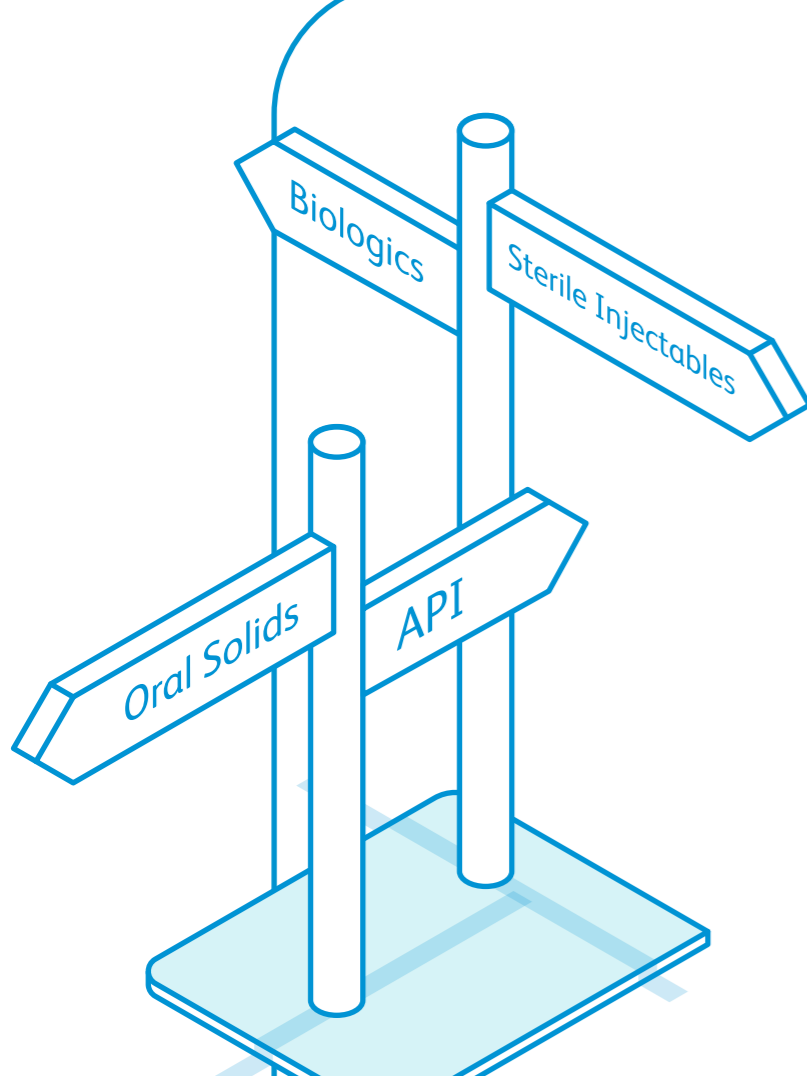

8.

## Embedded CDMO means embedded in bureaucracy

A certain amount of bureaucracy is necessary in drug development to maintain regulatory compliance and product quality. It's not red tape when patient and colleague safety are at stake. We provide access to high-performance quality and safety regimes - that means a more reliable and often faster route to market.

#courage

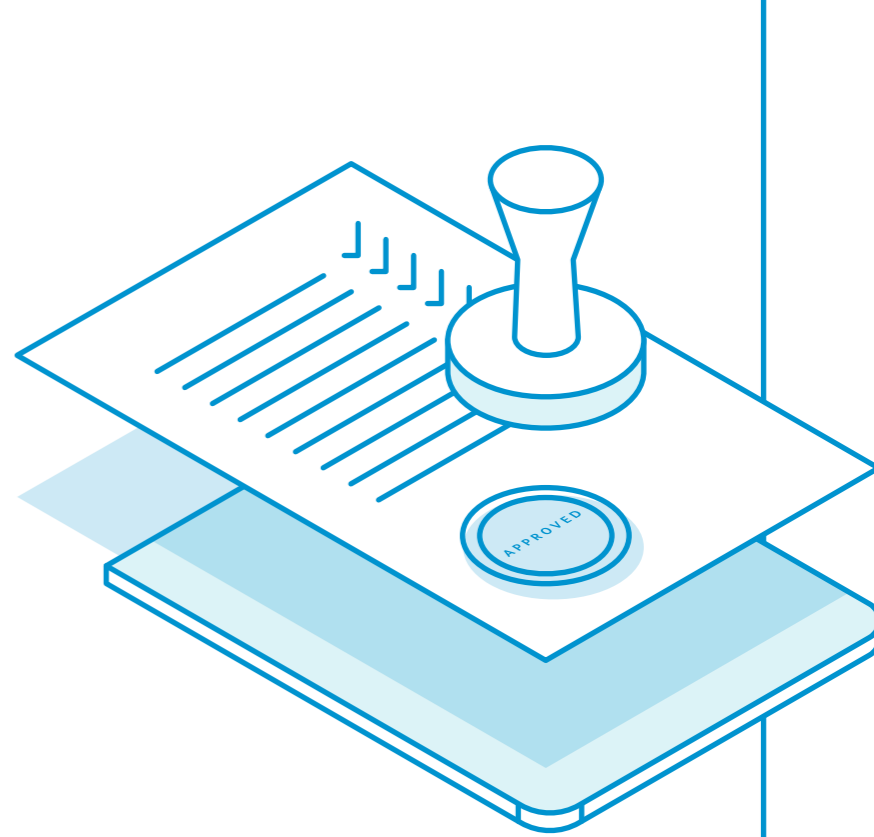

### Courage

Breakthroughs start by challenging convention, especially in the face of uncertainty or adversity. This happens when we think big, speak up and are decisive.

### Excellence

We can only change patients' lives when we perform at our best together. This happens when we focus on what matters, agree who does what and measure our outcomes.

### Equity

We believe that every person deserves to be seen, heard and cared for. This happens when we are inclusive, act with integrity and reduce health care disparities.

### Joy

We give ourselves to our work, but it also gives to us. We find joy when we take pride, recognize one another and have fun.